

MODVLS

Pumping station 1-way "Solar 1"

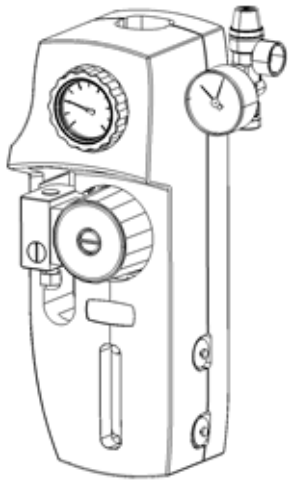

Epp insulation box

Measurements 150x425x150.

Box with a special bracket to fasten the unit and with the groove for the cable.

Cover with the opening for the cable press. (The cable press must be positioned towards the down, see the picture). Side opening for the security unit. A special window allows to read and to regulate the flow without removing the cover.

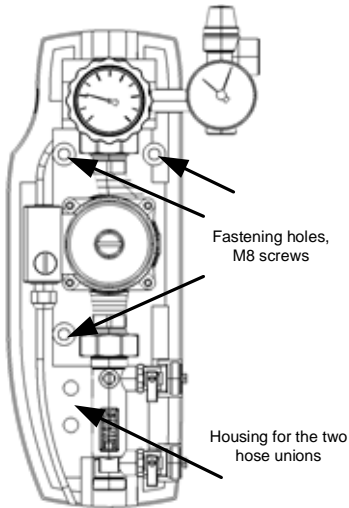

Fastening holes, M8 screws

Housing for the two hose unions

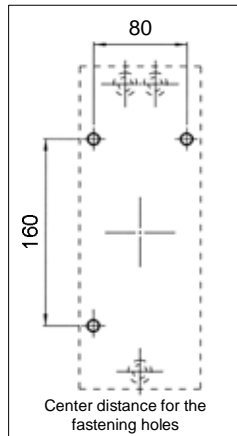

Center distance for the fastening holes

(A) all valve on the return way (thermoter with blue ring and scale 0-120°C) with "Solar" checkball.

Solar Checkball

It is included into the ball valve. It ensures the seal and low head losses. To exclude the checkball valve, for instance in case of emptying rotate the handle by 45° clockwise.

(D) Circulating pump

Three speed circulating pump with manual regulation. Thanks to the seal of the ball valves before and after the circulating pump, it can be removed without emptying the installation.

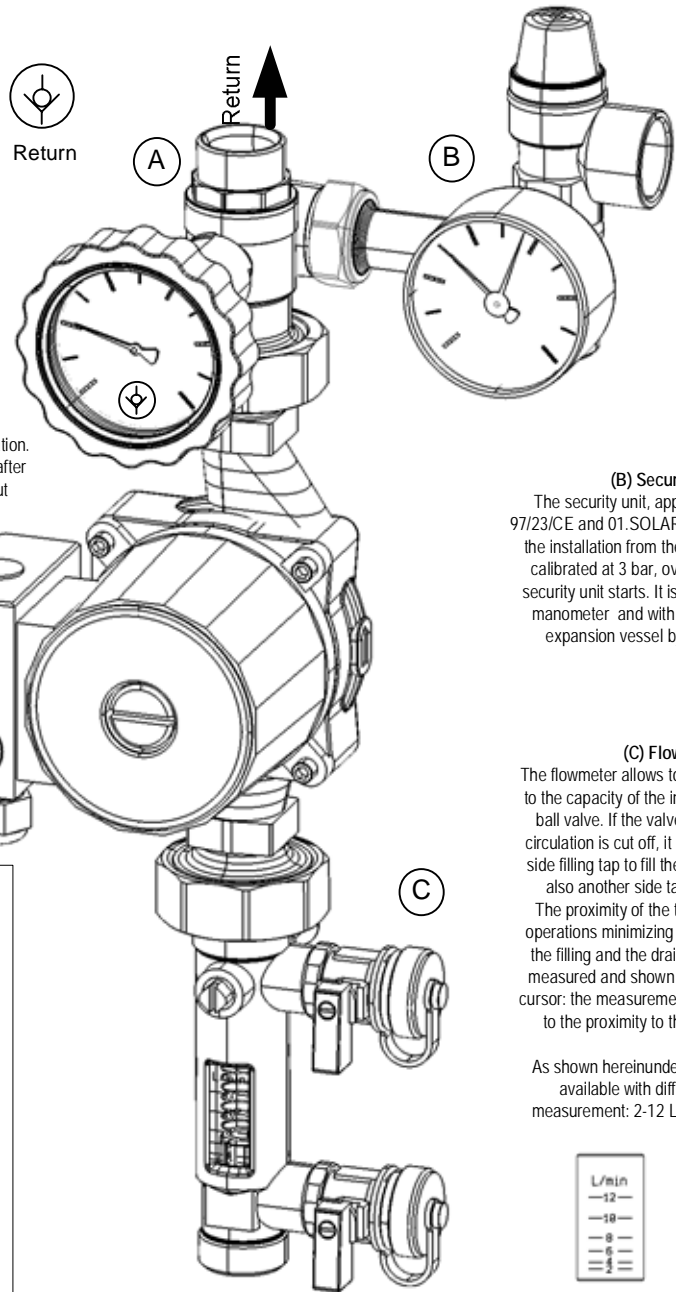

(B) Security unit

The security unit, approved according to 97/23/CE and 01.SOLAR 02.146 TÜV, protects the installation from the overpressures. It is calibrated at 3 bar, over this pressure the security unit starts. It is also provided with a manometer and with a connection to the expansion vessel by a 3/4" flexible kit.

(C) Flowmeter

The flowmeter allows to regulate the flow rate to the capacity of the installation, by a 3-way ball valve. If the valve is closed the usual circulation is cut off, it is possible to use the side filling tap to fill the installation. There is also another side tap, for the draining.

The proximity of the two taps helps these operations minimizing the distance between the filling and the draining. The flow rate is measured and shown by the special sliding cursor: the measurement is immediate thanks to the proximity to the regulation valve.

As shown hereinunder two flowmeters are available with different intervals of measurement: 2-12 L/min and 8-28 L/min.

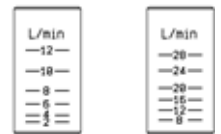

Directions for the use of the flowmeter to fill the installation:

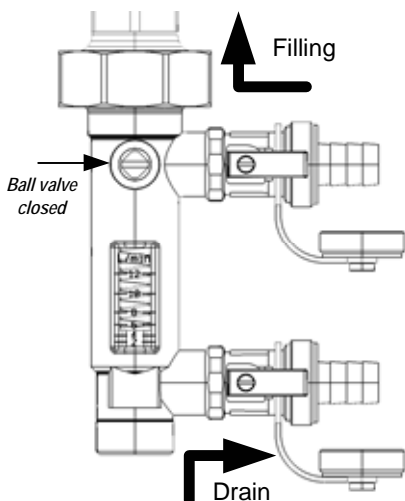

(1) - Filling the installation:

Remove the plugs from the side valves and connect the hose unions. Close the ball valve and open the side filling valve and draining valve.

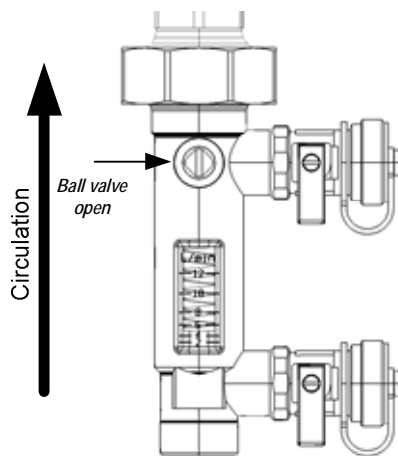

(2) - Starting the installation working:

Open the ball valve and close the side filling and draining valves. Remove the hose unions and screw again the plugs. To avoid any casual opening of the side valves, it is better to stop the levers in the close position, as shown here aside.

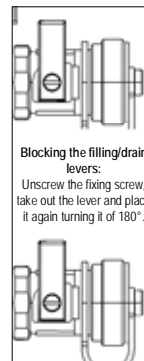

Blocking the filling/drain levers:
Unscrew the fixing screw, take out the lever and place it again turning it of 180°.

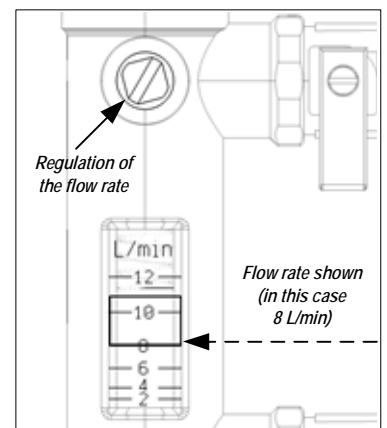

(3) - Regulate the flow rate using the regulation rod until the right flow rate is shown.

N.B. The flow rate is shown taking as reference the lower edge of the sliding cursor. (see picture)